

027R9610

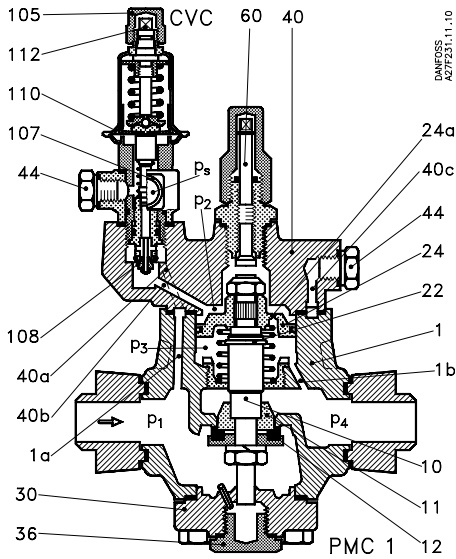

Fig. 1
PMC 1 + CVC

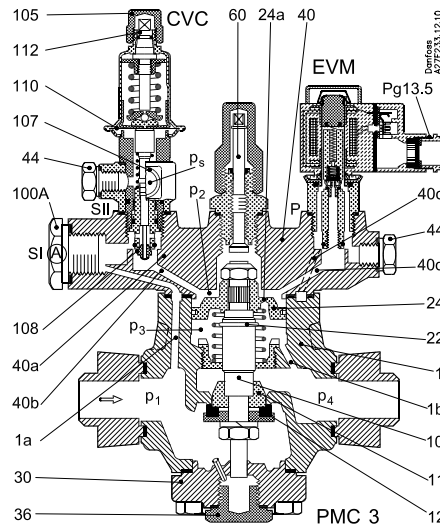

Fig. 2
PMC 3 + CVC + EVM

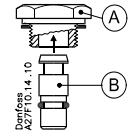

Fig. 3
A + B

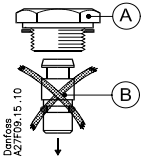

Fig. 4
A

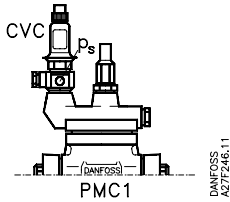

Fig. 5
PMC 1 + CVC

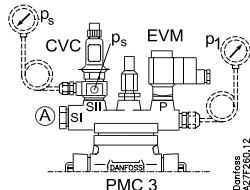

Fig. 7
PMC 3 + A + CVC + EVM

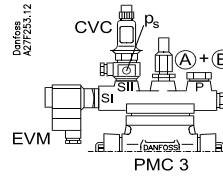

Fig. 9
PMC 3 + EVM + CVC + A + B

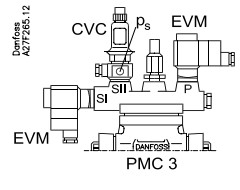

Fig. 11
PMC 3 + EVM + CVC + EVM

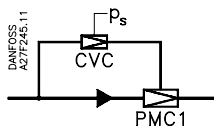

Fig. 6
PMC 1 + CVC

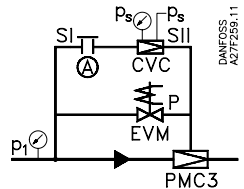

Fig. 8
PMC 3 + A + CVC + EVM

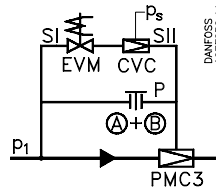

Fig. 10
PMC 3 + EVM + CVC + A + B

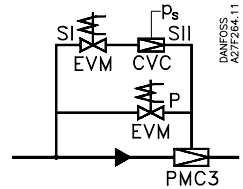

Fig. 12
PMC 3 + EVM + CVC + EVM

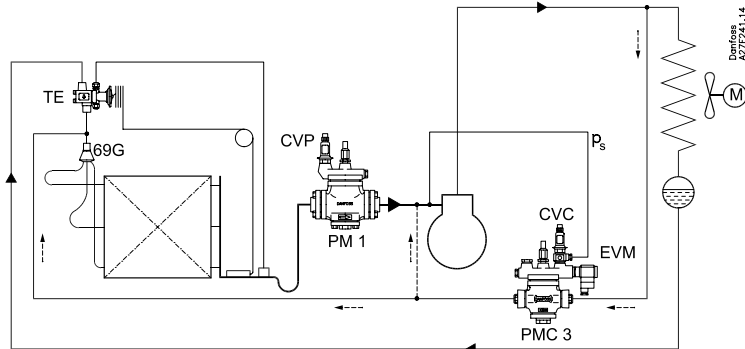

Fig. 13

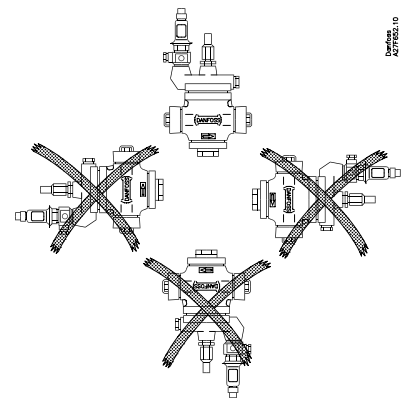

Fig. 14

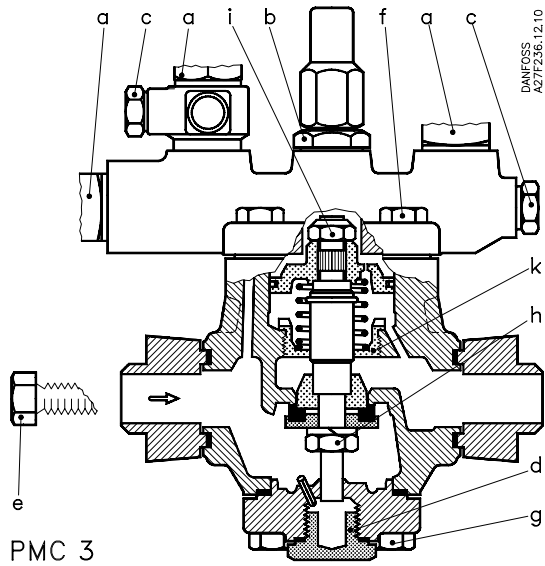

Fig. 15

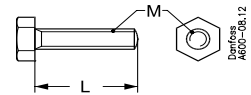

Fig. 16

Table I

Pos. Item.	Tightening torque in Nm (1 Nm = 0.74 lb force ft)			
	PMC 1 / PMC 3 Size			
	5	8	12	20
a	50			
b	50			
c	30			
d	50			
e	60			
f	40			
g	40			
h	35			
i	30			
k	60			

**Pilot-controlled capacity regulators
Main valves**

Design

See figs. 1 and 2.

1. Valve body
- 1a. and 1 b. Channels in valve body (1)
10. Pressure rod
11. Throttle cone
12. Valve seat
22. Locking ring
24. Servo piston
- 24a. Equalising hole in servo piston
30. Bottom cover
36. Drain plug
40. Cover
- 40a. b, c and d. Channels in cover (40)
44. Seal plug for manometer connection
60. Manual operating spindle
100. Seal plug
105. Seal cap
107. Signal line connection
108. Pilot orifice
110. Diaphragm
112. Setting spindle

Refrigerants

Applicable to all common non-flammable refrigerants, including R717 and non-corrosive gases/liquids dependent on sealing material compatibility.

Flammable hydrocarbons are not recommended. The valve is only recommended for use in closed circuits. For further information please contact Danfoss.

Temperature range

PMC 1/PMC 3:
-60/+120°C (-76/+248°F)

Pressure range

PMC 1/PMC 3: The valves are designed for a max. working pressure of 28 bar g (406 psi g).

Technical data

PMC 1 and PMC 3 are used in hot-gas lines. *PMC 1* controls the capacity with modulation depending on the control impulse of the connected CVC pilot valve. See figs. 1, 5 and 6. At a drop in pressure p_s in the signal line the diaphragm, 110, activates the pressure pin in the pilot orifice, 108, which opens. This results in a rise in pressure across the servopiston, 24, and PMC 1 opens. At a rise in pressure p_s in the signal line PMC 1 closes. It must not be possible to block the signal line. *PMC 3* controls the capacity with modulation depending on the control impulses of the connected pilot valves. See figs. 2 and 7 through 12. The CVC pilot valve must always be fitted in SII. Depending on where the EVM pilot valves are fitted, the following three functions can be obtained:

1. Plug A in SI, CVC in SII, EVM in P: Modulating capacity control combined with valve open override. See figs. 7 and 8.
2. EVM in SI, CVC in SII, plug A+B in P: Modulating capacity control combined with valve closed override. See figs. 9 and 10.
3. EVM in both SI and P, CVC in SII: Modulating capacity control combined with valve open and valve closed override. See figs. 11 and 12.

The PMC 1/PMC 3 has three connections for pilot valves: two in series, marked "S I" and "S II", and one in parallel with these two, marked "P", see figs. 1 and 2.

Schematic examples of pilot valves connected to the PMC 1/PMC 3 can be seen in figures 6, 8, 10, and 12.

If only two pilot valves are necessary for the function required, the third pilot connection must be sealed with a blanking plug (see fig. 5 and 7). A blanking plug is supplied with the valve.

Regulation range

Regulation range	Depends on the pilot valve. The CVC pilot valve is supplied with the regulation range $p_s = 0.45$ bar to +7 bar
Proportional-band	Approx. 0.2 bar

Installation

Flange set for the PMC 1/PMC 3 is delivered separately. The valve must be installed with the arrow in the direction of the flow and the top cover upwards (fig. 14). The top cover can be rotated 4 X 90° in relation to the valve body.

The accompanying gaskets for CVC must be fitted before mounting in SII. The O-ring must be lubricated with refrigeration oil.

The valve is mounted in a bypass between the high and low-pressure sides of the compressor with flow in the direction of the arrow and the top cover facing upwards. See fig. 13. The signal line is connected to the suction line between evaporator and compressor. If an evaporating pressure regulator is used, the signal line is connected between regulator and compressor.

If it is chosen to induce the hot gas into the suction line between evaporator and compressor it may be necessary to safeguard against excessive discharge tube temperatures by injecting liquid into the suction line, e.g. by means of the thermostatic injection valve type TEAT.

Type PMC is equipped with a spindle, 60, for manual opening.

Setting

When the seal cap, 105, has been removed, the regulator can be set. Turning the setting spindle, 112, clockwise will tighten the spring and the

regulator will begin to open at a higher suction pressure. One turn ~1.5 bar.

The valve is designed to withstand a high internal pressure. However, the piping system should be designed to avoid liquid traps and reduce the risk of hydraulic pressure caused by thermal expansion. It must be ensured that the valve is protected from pressure transients like "liquid hammer" in the system.

Welding

If using welding flanges, only materials and welding methods, compatible with the flange material must be welded to the flanges. The flanges should be cleaned internally to remove welding debris on completion of welding and before the valve is inserted.

The valve housing and flanges must be free from stresses (external loads) after installation.

PMC 1/PMC 3 valves must not be mounted in systems where the outlet side of the valve is open to atmosphere. The outlet side of the valve must always be connected to the system or properly capped off, for example with a welded-on end plate.

Colours and identification

The PMC 1/PMC 3 valves are Zinc-Chromated in the factory. If further corrosion protection is required, the valves can be painted. Precise identification of the valve is made via the ID plate on the top cover. The external surface of the valve housing must be prevented against corrosion with a suitable protective coating after installation and assembly.

Protection of the ID plate when repainting the valve is recommended.

Maintenance

Service

The PMC 1/PMC 3 valves are easy to dismantle and most of its parts are replaceable.

Do not open the valve while the valve is still under pressure.

- Check that the O-ring has not been damaged.
- Check that the spindle is free of scratches and impact marks.
- If the teflon ring has been damaged, the parts must be replaced.

Assembly

Remove any dirt from the body before the valve is assembled. Check that all channels in the valve are not blocked with articles or similar.

Tightening

Tightening torques
See fig. 15 and table I.

Use only original Danfoss parts, including packing glands, O-rings and gaskets for replacement. Materials of new parts are certified for the relevant refrigerant.

In cases of doubt, please contact Danfoss.

Danfoss accepts no responsibility for errors and omissions. Danfoss Industrial Refrigeration reserves the right to make changes to products and specifications without prior notice.

DECLARATION OF CONFORMITY
The Pressure Equipment Directive 97/23/EC



Name and Address of Manufacturer within the European Community

Danfoss Industrial Refrigeration A/S
Stormosevej 10
PO Box 60
DK-8361 Hasselager
Denmark

Declaration

We hereby declare that below-mentioned equipment are classified for Fluid Group I (all refrigerants (toxic, non-toxic, flammable and non-flammable)), and that all are covered by Article 3, paragraph 3.

For further details / restrictions - see Installation Instruction

Description of Pressure Equipment

Refrigerant main regulating valves
Type **PM, PMC, PMFH, PMFL, MRV, MEV**

Nominal bore **DN ≤ 25 mm.** (1 in)

References of other Technical Standards and Specifications used

prEN 12284 DIN 3158
EN 1563 AD-Merkblätter

Authorised Person for the Manufacturer within the European Community

Name: Morten Steen Hansen **Title:** Production Manager

Signature: Morten Steen Hansen **Date:** 16/01/2002

148B9715 - rev. 1

DECLARATION OF CONFORMITY
The Pressure Equipment Directive 97/23/EC



Name and Address of Manufacturer within the European Community

Danfoss Industrial Refrigeration A/S
Stormosevej 10
PO Box 60
DK-8361 Hasselager
Denmark

Description of Pressure Equipment

Refrigerant main regulating valves
Type PM, PML, PMLX, PMFH, PMFL, MRV, MEV

Nominal bore	DN32-150 mm (1 ¹ / ₄ - 6 in.)	
Classified for	Fluid Group I (all refrigerants (toxic, nontoxic, flammable and nonflammable)). For further details / restrictions - see Installation Instruction.	
Temperature range	All	-60°C (-76°F) to 120°C (248°F)
Maximum allowable working pressure		28 bar (406 psi)

Conformity and Assessment Procedure Followed

Category	II	III
Module	D1	B1+D
Certificate ID	D1: 07 202 0511 Z 0009/1/H-0002	B1: 07 202 0511 Z 0074/1/H-0001 D: 07 202 0511 Z 0009/1/H-0001
Nominal bore	DN 32-125 mm (1 ¹ / ₄ -5 in)	DN150 mm (6 in)

Name and Address of the Notified Body which carried out the Inspection

TÜV-Nord e.V.
Grosse Bahnstrasse 31
22525 Hamburg, Germany



Name and Address of the Notified Body monitoring the Manufacturer's Quality Assurance System

TÜV-Nord e.V.
Grosse Bahnstrasse 31
22525 Hamburg, Germany

References of Harmonised Standards used

References of other Technical Standards and Specifications used

prEN 12284 DIN 3158
EN 1563 AD-Merkblätter

Authorised Person for the Manufacturer within the European Community

Name: Morten Steen Hansen **Title:** Production Manager

Signature: Morten Steen Hansen **Date:** 16/01/2002